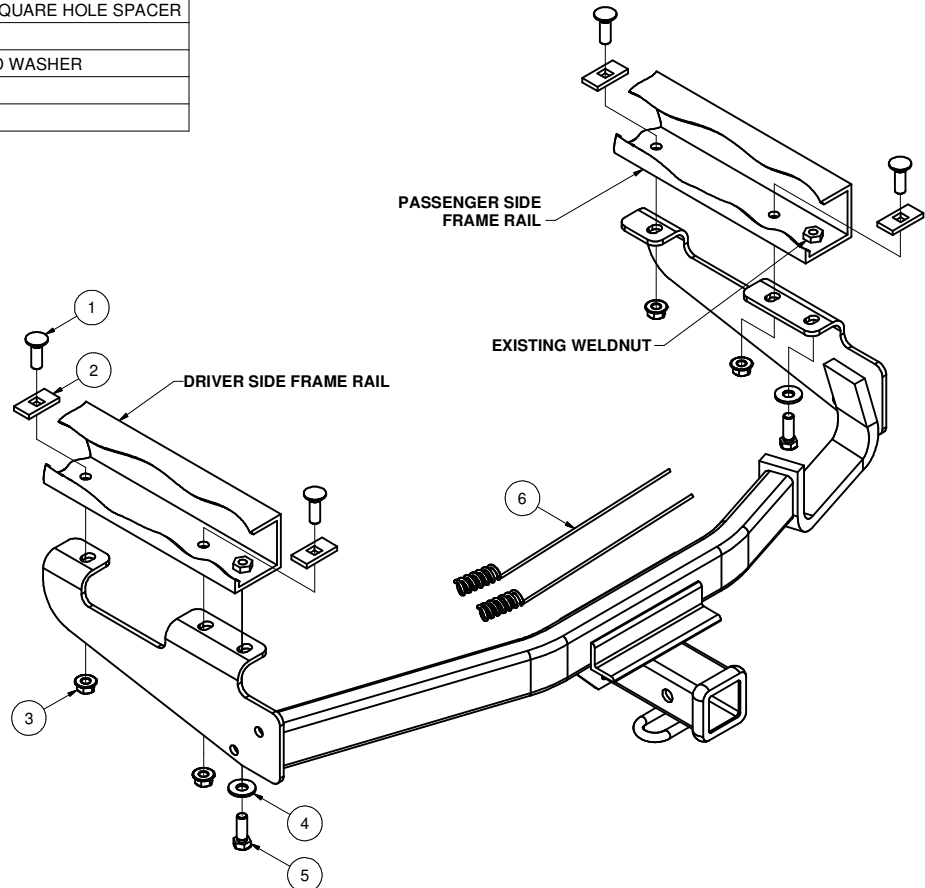
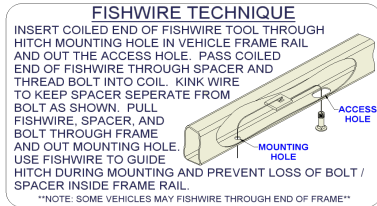

13362**96-07 CHRYSLER TOWN & COUNTRY VAN, 96-04 PLYMOUTH VOYAGER VAN,
96-07 DODGE CARAVAN (EXCEPT STOW & GO, AND SPORT MODELS)**

1/17/2013

**GROSS LOAD CAPACITY WHEN USED AS A WEIGHT CARRYING HITCH: 4,000 LBS. TRAILER WEIGHT & 400 LBS. TONGUE WEIGHT.
GROSS LOAD CAPACITY WHEN USED AS A WEIGHT DISTRIBUTION HITCH: 5,000 LBS. TRAILER WEIGHT & 500 LBS. TONGUE WEIGHT*******DO NOT EXCEED VEHICLE MANUFACTURER'S RECOMMENDED TOWING CAPACITY.*****

Parts List			
ITEM	QTY	PART NUMBER	DESCRIPTION
1	4	1/2-13 x 1 1/2	CARRIAGE BOLT
2	4	CM-SP12	.250 x 1.00 x 2.00" SQUARE HOLE SPACER
3	4	HFN 1213	HEX FLANGE NUT
4	2	1/2"	CONICAL TOOTHED WASHER
5	2	M12-1.75 x 35mm	HEX BOLT
6	2	1/2"	FISHWIRE TOOL

HITCH WEIGHT: 34 LBS.INSTALL TIME: 20 MINUTES

INSTALL NOTES:

- DRILLING MAY BE REQUIRED

- FISHWIRE HARDWARE

INSTALLATION STEPS

- 1) REMOVE THE REAR MOST BUMPER BRACKET BOLT FROM THE UNDERSIDE OF THE FRAME. (BOTH SIDES.) THIS BOLT WILL BE REPLACED WITH A NEW BOLT LATER IN THE INSTALLATION.
- 2) LOCATE THE REMAINING MOUNTING HOLE LOCATIONS. INCLUDING THE PREVIOUSLY REMOVED BOLT THERE SHOULD BE THREE PER SIDE. IN SOME VEHICLES ONE OR MORE OF THE MOUNTING HOLES MAY HAVE TO BE DRILLED. IF DRILLING IS REQUIRED USE THE HITCH AS A TEMPLATE TO MARK THE HOLE LOCATIONS. THESE HOLES SHOULD BE DRILLED OUT WITH A 9/16" DRILL BIT.
- 3) WHEN ALL REQUIRED MOUNTING HOLES ARE PRESENT, USE THE FISHWIRE TOOL PROVIDED TO INSERT THE CARRIAGE BOLTS AND SPACERS THRU THE FRAME ACCESS SLOT AND OUT THE PROPER MOUNTING HOLES. IF THE ACCESS HOLE IS NOT AVAILABLE, ENLARGE THE SQUARE HOLE IN FRAME, OR FISHWIRE THROUGH THE END OF THE VEHICLE FRAME BEHIND THE BUMPER. **NOTE: THERE IS A FLEXIBLE PLASTIC FLAP THE HARDWARE MUST PASS BY.** REARMOST CARRIAGE BOLT SHOULD BE INSTALLED IN THE AVAILABLE FRAME SLOT LOCATED BETWEEN THE BUMPER BRACKET BOLTS.
- 4) RAISE THE HITCH INTO POSITION AND ATTACH IT TO THE FRAME USING 1/2" FLANGE NUTS.
- 5) INSTALL THE M12 HEX BOLT AND 1/2" CONICAL LOCKWASHER PROVIDED THRU THE HITCH AND INTO THE BUMPER BRACKET.
- 6) TORQUE THE 1/2" HARDWARE TO 110 LB/FT AND THE M12 HARDWARE TO 79 LB/FT.

**PERIODICALLY CHECK THIS RECEIVER HITCH TO ENSURE THAT ALL FASTENERS
ARE TIGHT AND THAT ALL STRUCTURAL COMPONENTS ARE SOUND.**

Curt Manufacturing Inc., warrants this product to be free of defects in material and/or workmanship at the time of retail purchase by the original purchaser. If the product is found to be defective, Curt Manufacturing Inc., may repair or replace the product, at their option, when the product is returned, prepaid, with proof of purchase. Alteration to, misuse of, or improper installation of this product voids the warranty. Curt Manufacturing Inc.'s liability is limited to repair or replacement of products found to be defective, and specifically excludes liability for incidental or consequential loss or damage.